

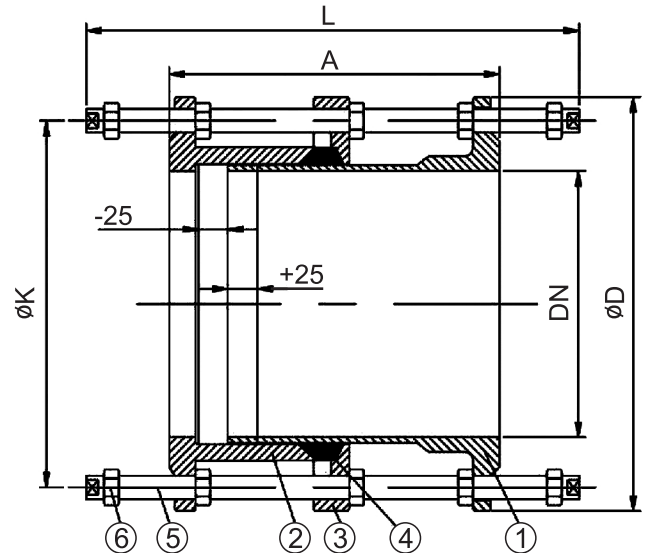

Dismantling joints "DJ - F3"

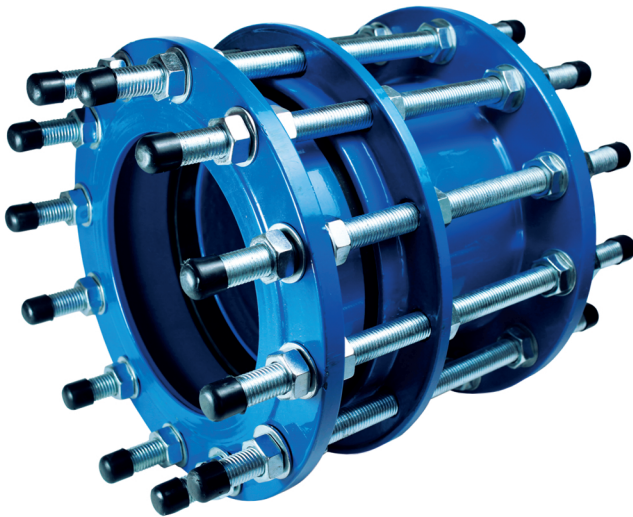

USE:

- Water supply networks. Flanged connections of pipes of the same diameter. Used to facilitate assembly and disassembly of the fittings.

MATERIALS:

- 1 - body - ductile cast iron protected with epoxy powder coating,
- 2 - flange - ductile cast iron protected with epoxy powder coating,
- 3 - retaining flange - ductile cast iron protected with epoxy powder coating,
- 4 - gasket - EPDM rubber,
- 5,6 - bolts and nuts - galvanized steel,
- optional: stainless steel.

The product has been certified as suitable for contact with potable water.

DN	PN10			PN16			Product code
	Length [mm] A	Diameter [mm] D	Diameter [mm] K	Length [mm] A	Diameter [mm] D	Diameter [mm] K	
80	200	200	160	200	200	160	
100	200	220	180	200	220	180	
125	200	250	210	200	250	210	
150	200	285	240	200	285	240	
200	220	340	295	220	340	295	
250	220	400	350	230	400	355	
300	220	455	400	250	455	410	
350	230	505	460	260	520	470	
400	230	565	515	270	580	525	
450	250	615	565	270	640	585	
500	260	670	620	280	715	650	
600	260	780	725	300	840	770	
700	260	895	840	300	910	840	
800	290	1010	950	320	1025	950	
900	290	1115	1050	320	1125	1050	
1000	290	1230	1160	340	1255	1170	
1200	320	1455	1380	360	1485	1390	