

ZŁĄCZE KOŁNIERZOWE "FABO"

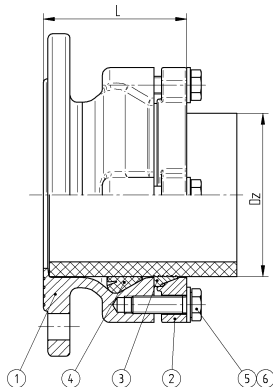

MATERIAŁY:

- 1-2 Korpus, kołnierz – żeliwo sferoidalne zabezpieczone farbą proszkową epoksydową.
- 3. Pierścień zaciskowy – mosiądz.
- 4. Uszczelka - guma EPDM lub NBR.
- 5,6 Śruba, podkładka – stal nierdzewna.

INSTRUKCJA MONTAŻU

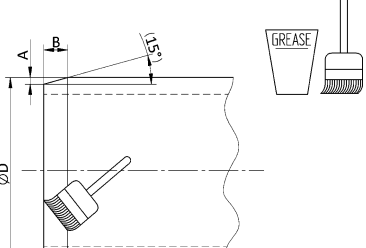
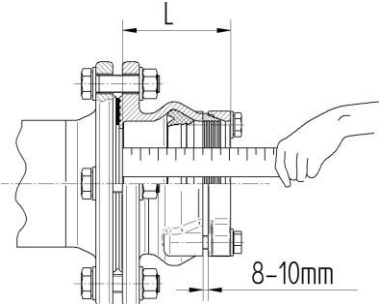
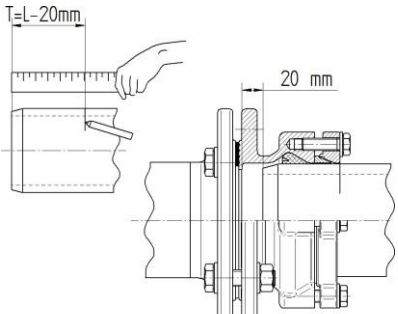
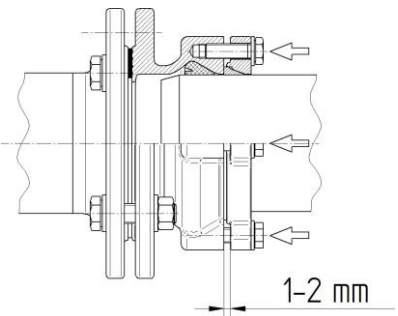
1.	 <table border="1" data-bbox="574 801 798 952"> <thead> <tr> <th>ØD</th> <th>A</th> <th>B</th> </tr> </thead> <tbody> <tr> <td>63-140</td> <td>2,5</td> <td>10</td> </tr> <tr> <td>160-180</td> <td>4</td> <td>16</td> </tr> <tr> <td>200-225</td> <td>5</td> <td>20</td> </tr> <tr> <td>250-315</td> <td>7</td> <td>25</td> </tr> </tbody> </table>	ØD	A	B	63-140	2,5	10	160-180	4	16	200-225	5	20	250-315	7	25	<p>Zukosować końce rur w zależności od wymiaru wg tabeli.</p> <p>Usunąć zadziory i posmarować rurę smarem.</p>
ØD	A	B															
63-140	2,5	10															
160-180	4	16															
200-225	5	20															
250-315	7	25															
2.		<p>Zmierzyć głębokość złącza L.</p>															
3.		<p>Zaznaczyć na rurze głębokość wsunięcia $T = L - 20\text{mm}$.</p> <p>Wsunąć rurę do zaznaczonej głębokości.</p>															
4.		<p>Dokręcić śruby po przekątnej „na krzyż” do zaciśnięcia pierścienia.</p> <p>Wartości momentów dokręcenia wg tabeli.</p>															
<table border="1"> <thead> <tr> <th>M10</th> <th>M12</th> <th>M14</th> <th>M16</th> </tr> </thead> <tbody> <tr> <td>40Nm</td> <td>60Nm</td> <td>80Nm</td> <td>150Nm</td> </tr> </tbody> </table>		M10	M12	M14	M16	40Nm	60Nm	80Nm	150Nm								
M10	M12	M14	M16														
40Nm	60Nm	80Nm	150Nm														